

Classic Update Series

1968-1972 GTO

START HERE !

PLEASE READ THIS BEFORE STARTING INSTALLATION !

This wiring kit is designed for ease of installation. Please read the guidelines below, BEFORE STARTING your installation to guarantee a successful job. Use an appropriate crimping tool which folds the wings of the open barrell terminals down into the wire as shown below. ALL TERMINALS THAT YOU INSTALL SHOULD BE PROPERLY SOLDERED. Our factory crimped terminations are installed by GM approved five ton presses, and soldering these terminations is not necessary. AAW offers a great terminal crimping video entitled "Proper Crimping Video". It can be viewed by visting YouTube. Type the following address into your web browser to go directly to the video: www.youtube.com/watch?v=8u_EkMsioMy.



AS THIS HARNESS IS DESIGNED FOR USE IN A MODIFIED CAR REQUIRING A HIGHER RATE OF CHARGE, IT DOES NOT SUPPORT THE USE OF A STOCK (ORIGINAL) EXTERNALLY REGULATED ALTERNATOR. IT IS DESIGNED FOR USE WITH AN INTERNALLY REGULATED "SI" OR SINGLE WIRE STYLE ALTERNATOR. IT CAN ALSO BE USED WITH THE LATER "CS" AND "CS-D" UNITS BY USING ALTERNATOR ADAPTERS WHICH ARE SOLD SEPARATELY. CONTACT AAW OR YOUR FAVORITE DEALER FOR THE PROPER ALTERNATOR ADAPTER FOR YOUR CAR.

STEP 1: DISCONNECT YOUR BATTERY:

Disconnect the battery before installing the wiring kit to prevent any accidental shorting caused by loose bare wire ends.

STEP 2: START INSTALLING KIT:

This kit is broken down into individual steps that are identified by a letter printed on the instruction sheets visible through each bag. These letters are the order of operation for installaing your kit. Start with bag letter G, then H, etc. The order of installation is shown below.

G 510541 Dash Harness Kit
H 510542 Instrument Cluster Kit
J 510543 Engine Kit
L 510544 Front Light Kit
M 510545 Rear Body Kit
N 500708 Courtesy Light Kit
Z 510476 Alternator and Main Power Connection Kit.

STEP 3: RECONNECT YOUR BATTERY:

When you have completed the installation and are ready to reconnect the battery, make sure that the following electrical system grounds are in place:

A. Battery is grounded to the ENGINE BLOCK.
B. Battery is grounded to the frame.
C. Engine block is grounded to the frame.
D. Body is grounded to the frame.

STEP 4: CHECK ALL ELECTRICAL FUNCTIONS:

Any non-functioning items should be checked for proper installation. Any problems with your wiring and electrical circuit functions should be addressed to American Autowire Systems, Inc. as soon as possible to avoid any warranty problems.

If you have any questions concerning this or any of our products, please feel free to call us at 1-856-933-0801.

AMERICAN AUTOWIRE MAKES IT EASY !!

We carry many accessories for your 1968-1972 GTO

p/n R0067108
OEM style non-stick harness tape



p/n 01993371 (1968) with recessed park
p/n 01993425 (1968) w/o recessed park
OEM style wiper switch.

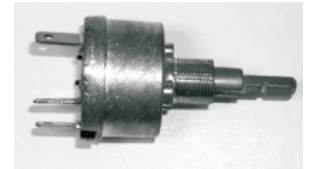

p/n 03943657 (196-72)
Muncie 4 speed back up lamp switch.



p/n 500649
OEM small terminal crimping
tool (18-14 gauge).



p/n 500523
OEM large terminal crimping
tool (12-8 gauge).



p/n 38131
Breakerless Ignition Module,
GM V-8 POINT CONVERSION KIT



p/n 38571 (1969)
p/n 36359 (1970)
p/n 36360 (1971)
Factory assembly manual.
(It's what they used on the assembly
line to build your GTO!)



www.americanautowire.com 856-933-0801

Classic Update Series

1968-1972 GTO

510540

© COPYRIGHT 2004 American Autowire / Factory-Fit
Used with express permission of
American Autowire / Factory-Fit
92970626 instruction sheet rev. 1.0 1/26/2018

Classic Update Series

1968-1972 GTO



www.americanautowire.com 856-933-0801

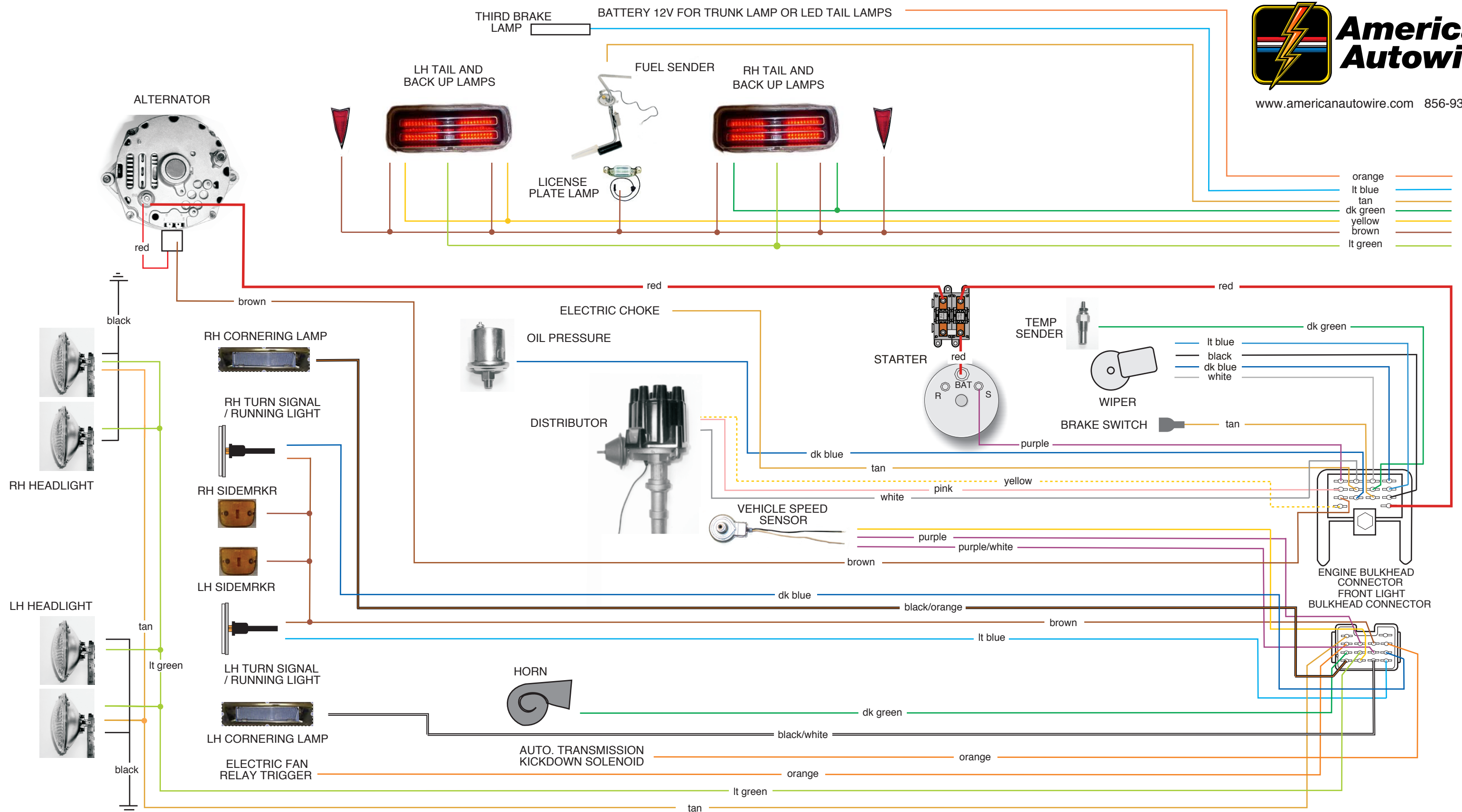

NOTICE: This schematic drawing is for reference only. Do not use the schematic to install this wiring kit! Use the instruction sheets included in each bag, which includes directions for proper terminations, connector indexing, and specific applications.

510540

THIS PAGE HAS BEEN
INTENTIONALLY LEFT BLANK



www.americanautowire.com 856-933-0801

510540

© COPYRIGHT 2004 American Autowire / Factory-Fit
Used with express permission of American Autowire / Factory-Fit
92970626 instruction sheet rev. 1.0 1/26/2018